

Simulation of Gas Turbine Power Plant Using High Pressure Fogging Air Intake Cooling System

E.N. Achimmole¹, E.K. Orhorhoro¹, M.O. Onogbotsere²

¹Department of Mechanical Engineering, University of Benin, Benin City, Nigeria

²Department of Electrical/Electronic Engineering, Delta State Polytechnic, Otefe-Oghara, Nigeria

*Corresponding Author: Ejiroghene Kelly Orhorhoro, Department of Mechanical Engineering, University of Benin, Nigeria

Received Date: 15-07-2017

Accepted Date: 24-07-2017

Published Date: 25-09-2017

ABSTRACT

This research work focus on the simulation of a gas turbine power plant using high pressure fogging air intake cooling system. Aspen HYSYS software was used for the simulation of the gas turbine with and without cooling system using the actual operating data for performance evaluation. The results obtained on the simulation of the gas turbine at ambient air temperature of 25.69°C without the use of cooling system showed that ambient air temperature decreases the net power output, thermal efficiency and increases the specific fuel consumption and heat rate. However, when the gas turbine was incorporated with air intake cooling system (high pressure fogging), there was drop in ambient air temperature which resulted to an increase in net power output, thermal efficiency and reduction in specific fuel consumption and heat rate.

Keywords: Gas turbine, simulation, Aspen HYSYS software, thermal efficiency, specific fuel consumption, heat rate.

INTRODUCTION

Gas turbine performance is critically limited by temperature variation, especially in hot and rain region like Sub-Saharan. The increase in inlet air temperature become pronounced especially in the hot weather, and this causes a significant decrease in gas turbine power output. It occurs because the power output is inversely proportional to the ambient temperature and because of the high specific volume of air drawn by the compressor [1]. The efficiency and power output of gas turbines vary according to the ambient conditions [2]. The resulted amount of these variations greatly affects electricity generation, fuel consumption and plant incomes. However, cooling the air intake to the compressor has been widely used to mitigate this shortcoming [3].

The method of injecting water into the inlet duct of a gas turbine is now a well know established tool of air inlet cooling and this technique is called inlet fogging [4]. The fine mist of water droplets are referred to as fog, and is injected

into the air intake by a nozzle manifold, usually mounted near the air filters by injecting less or equal amount of water to what is required for saturating the intake air (at a given ambient conditions) [5]. This in turn reduces the compressor inlet temperature resulting in the regain of loss in the power output, efficiency, and reduction in specific fuel consumption, net heat rate [6]. The effectiveness of this measure depends on the air humidity and temperature, generally achieving maximal benefits in dry and hot climates but still delivering significant benefits in moist, tropical environments.

Ambient temperature, humidity and pressure are important factors that either reduce or improve the performance of gas turbine performance. Also, thermal efficiency decreases with an increase in ambient temperature [7]. Research has shown that ambient temperature has the greatest effect on gas turbine inlet-temperature and the pressure ratio [8]. Moreover, the work of Ibrahim et al. [7] also shows that an increase

of 1°C in the compressor air inlet temperature decreases the gas turbine power output by 1%. All these point to the evidence that gas turbine performance is sensitive to the ambient air temperature. As ambient temperature rises, less air can be compressed by the compressor and this results to drop in gas turbine performance [8]. Also, the compression work increases because the specific volume of the air increases in proportion to the intake air temperature [9]. In gas turbine, fogging system is mainly installed to ensure that power losses due to the high ambient temperature are regained. The relevance of air intake cooling (AIC) to compressor is that it allows reduction of losses in gas turbine (GT) power output, compared to the rated capacity when ambient temperature rises above 15°C or the plant is located in a warm/hot climate region. AIC can lead to an increase in gas turbine output above the rated capacity by cooling the inlet air below 15°C [10].

Sub-Sahara countries are located in tropical climate characterized by hot and rain weather, relative humidity. Gas turbines are rated to operate at ambient condition of 15°C, relative humidity of 60% and 101.32kPa at sea level of International Standard Organization ISO. But due to hot weather in this region, the ambient conditions under which gas turbine power plant operate have a noticeable effect on the plant performance. Thus, its power output, thermal efficiency, specific fuel consumption and net heat rate deteriorate at high intake air temperature when compared to ISO condition [11]. Cooling the intake air to compressor by incorporating of high fogging system is one of the cooling techniques propose to mitigate the effect of ambient temperature on gas turbine power plant. In this research work, the simulation of gas turbine power plant using high pressure fogging air intake cooling system will be carry out using Aspen HYSYS software. Aspen HYSYS is engineering software suite; one of these programs is Aspen plus, which allows for steady-state process modeling [12]. The user interface is predicated on a library of

ready-made user editable component models based in FORTRAN. By connecting these components by material heat and work streams and providing appropriate inputs, the user is able to model complex processes. Aspen is commonly used software platform for process modeling, particularly in the oil and gas industry, power generation companies etc. [12]. The decision to model high pressure fogging in ASPEN was based primarily on two advantages. First high pressure fogging models produced in ASPEN could be directly integrated with the plant cycle model. Secondly, ASPEN has an optimization capability that when used in future work, will aid in producing the design with the maximum energy savings.

MATERIALS AND METHODS

One year operating data of a gas turbine plant was used for this research work. Table 1 shows the summary of operating parameters of the turbine plant. The analysis of the plant is divided into different control volumes and performance of the plant is estimated using component wise modeling, mass and energy conservation laws is applied to each component and performance of the plant is determine for the simple gas turbine system and with incorporation of air intake cooling system (high fogging) in gas turbine power plant.

The basic gas turbine cycle is Brayton cycle; it consists mainly of compressor, combustion chamber and turbine. Air enters the compressor where it is compressed and heated after that its goes to the combustion chamber, where fuel is burned at constant pressure before it eventually raises the temperature of air to the firing temperature. The resulting high temperature gases enter the gas turbine where they expand to generate the useful work. The part of the work developed by the gases passing through the turbine is used to run the compressor and remaining (30 – 35%) is used to generate the electrical energy. Figure 1 shows the flow chart of the system while figure 2 shows modelling of gas turbine unit by incorporating high pressure fogging.

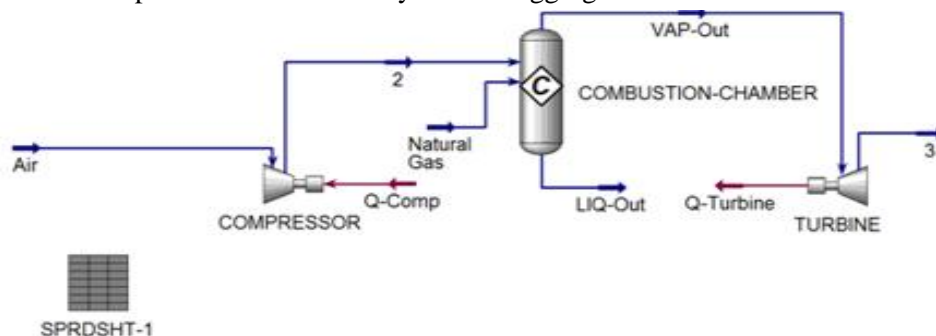

Figure1. Flow chart of simulated simple gas turbine

Simulation of Gas Turbine Power Plant Using High Pressure Fogging Air Intake Cooling System

Table1. Operating parameters of gas turbine power plant.

S/N	Operating parameters	Value	Unit
1	Mass flow rate of air through compressor \dot{m}_a	376.75	kg/s
2	Temperature of intake air to compressor T_1	298.69	K
3	Pressure of intake air to compressor p_1	101.3	KPa
4	Exit temperature of air compressor T_2	631.659	K
5	Exit pressure of air from the compressor p_2	982.804	kPa
6	Assumed pressure drop in combustion chamber	2%	
7	Fuel gas(natural gas)mass flow rate \dot{m}_f	6.7	kg/s
8	Temperature of fuel gas t_f	328	K
9	Pressure of fuel gas p_f	2280	kPa
10	Turbine temperature T_3	1363.428	K
11	Exhaust temperature T_4	829.637	K
12	Mass of exhaust \dot{m}_{exh}	383.45	kg/s
13	Lower heating value LHV	46670	kJ/kg
14	Isentropic efficiency of compressor	87.8	%
15	Isentropic efficiency of turbine	89.4	%
16	Combustion efficiency	99	%
17	Turbine pressure P_3	982.7844	KPa
18	Specific heat capacity of air C_{pa}	1.005	kJ/kgK
19	Specific heat capacity of gas C_{pg}	1.15	kJ/kgK
20	Pressure ratio	9.7	

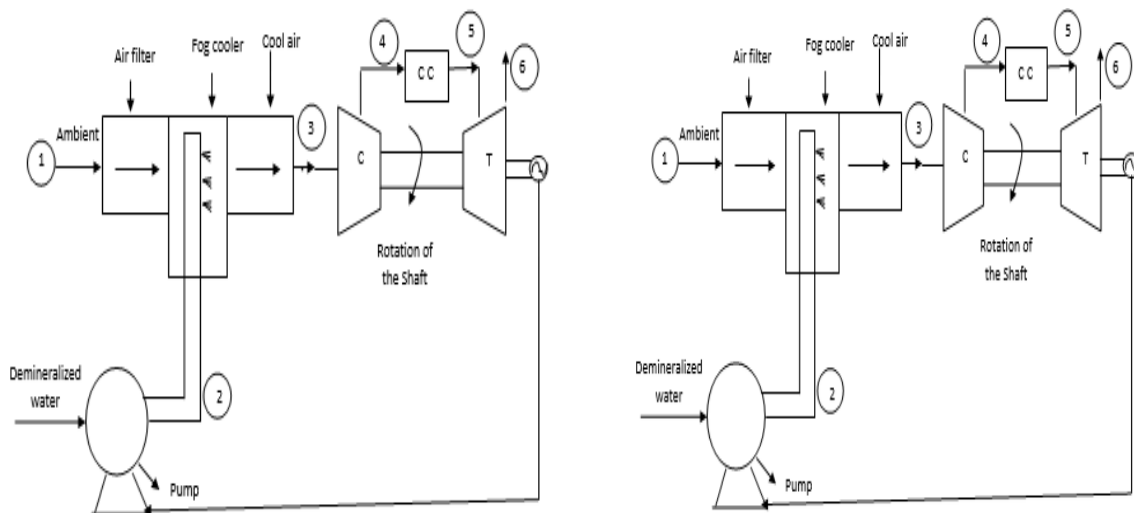

Figure2. Schematic diagram of fogging unit incorporates to gas turbine

The following assumptions were made in the simulation of the gas turbine with fogging system:

- Air contain 23.3% oxygen and 76.7% by mass
- The combustion of the process was assumed to be a conversion reaction in HYSYS.
- The conversion is 100% in the reactor.
- In the compressor the isentropic efficiency was 87.80%, while turbines isentropic efficiency was 89.40%.
- The component of the natural gas is Methane.
- The natural gas in the feed comes directly at the pressure of 22.8 bars and temperature of 55°C.
- Assumed mechanical loss of 97%

Simulation of Gas Turbine Power Plant Using High Pressure Fogging Air Intake Cooling System

- Assumed that there are no losses on the conversion energy.
- The pressure drop across the combustion chamber was assumed to be 2%.
- The pressure, ambient air temperature and mass flow rate of air are constant.

Aspen HYSYS was used to model the gas turbine and gas turbine with fogging units. The first step in creating the model was the selection of a standard set of components and a thermodynamic basis to model the physical properties of these components.

When the component list was created, HYSYS created a new component list called Component List-1. The next step was the selection of a 'Fluid Package' for it. The 'Fluid Package' which is the thermodynamic system associated with the chosen list of components. The

'Simulation Environment' was entered to begin building the process model. The Pump, Mixer, Separator, Compressor, Conversion Reactor, Turbine icons from the model palette were clicked and placed on the flow sheet in Figure 3. The combined units of mixer and separator are used to simulate a fogging unit: when the incoming air enters the fogging unit, the high pressure pump then convert the demineralized water to fog nozzle operating at high pressure, where it is spray to the hot air in the mixer. However, the hot air mixed with fog to ensure proper saturation of air before it leaves the mixer, saturated air then enter the separator where its separate the vapour and water, While the water that is not vaporized by the incoming hot air leaves the bottom of the fogging unit as shown in Figure 3. The fogging unit is shows in Figure 4.

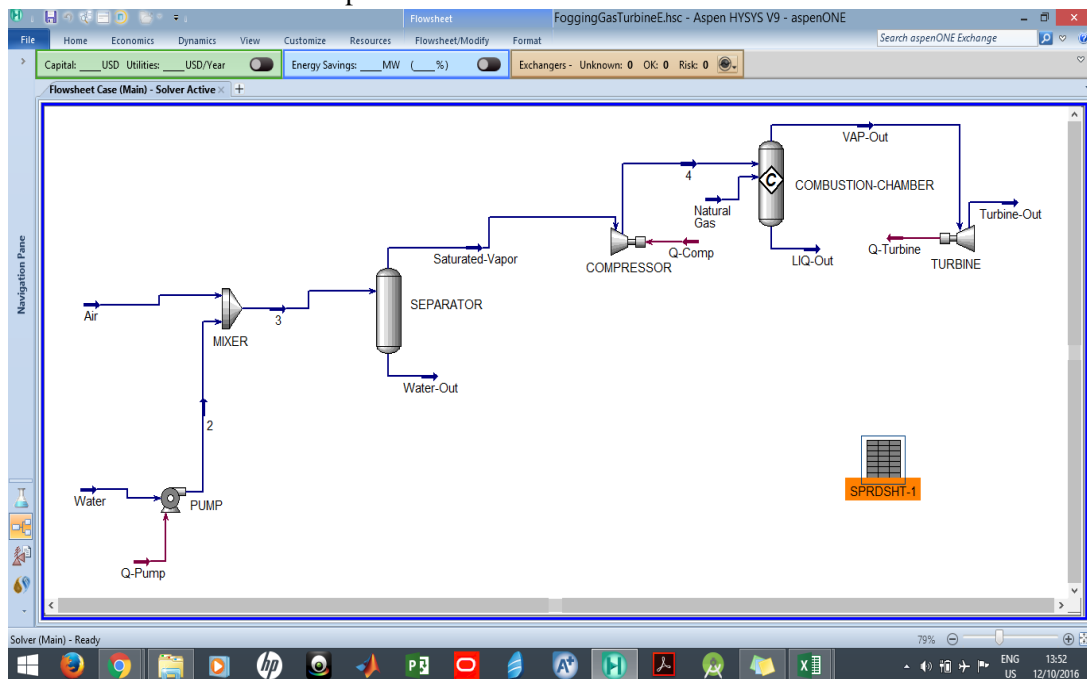

Figure3. Process Flow sheet for Gas Turbine with Fogging Unit.

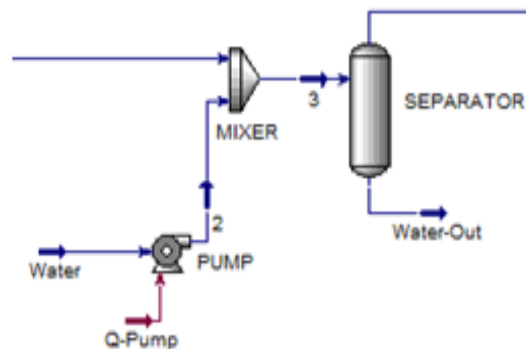

Figure4. Fogging Unit

RESULTS AND DISCUSSION

Aspen HYSYS software was used to simulate the performance of the plant. The result obtained is shown in Table 2 and Table 3. To understand the influence of a change in input variable such as temperature to the net power

output, thermal efficiency, specific fuel consumption and heat rate, sensitive analysis of the gas system turbine were done using Aspen. The results were used to compare the performance of the plant when it is incorporated with air intake cooling system (high pressure fogging).

Table2. Simulated results obtained at simple type gas turbine unit

Items	Value kw	Value Mw
Compressor power	138672.54	138.672
Turbine power	240786.990	240.786
Work net	99051.01378	99.051
Thermal efficiency	31.68%	
Specific fuel consumption SFC	0.2435 kg/kWh	
Net heat rate HR	11364.145 kJ/kWh	

Table 3 shows the result of simulation obtained with high pressure fogging while Table 4 shows the performance comparison with and without fogging system.

Table3. Simulated results obtained with high pressure fogging system.

Items	Unit kW	Unit MW
Compressor power	112193.9888	112.193
Turbine power	227662.6597	227.662
Net power output	112004	112.004
Thermal efficiency	35.82	%
Specific fuel consumption SFC	0.2153 kg/kWh	
Net heat rate	10048.051 kJ/kWh	

The analysis of the results with and without fogging system showed that with fogging, a drop in temperatures readings were recorded.

This indicates that with fogging system, the gas turbine is expected to perform better than gas turbine without a fogging system.

Table4. Comparative analysis with and without fogging system

Item	Without fogging	With fogging	units
Compressor exit temperature	631.659	565.1	K
Turbine temperature	1363.428	1283	K
Exhaust temperature	829.637	796.9	K
Compressor power	138.672	112.193	MW
Turbine power	240.786	227.662	MW
Net power	99.051	112.004	MW
Thermal efficiency	31.68	35.82	%
Specific fuel consumption	0.2435	0.2153	kg/kWh
Heat rate	11364.145	10048.051	kJ/kWh
Greenhouse gas GHG emission	8342.312	7376.179	Kg
Total mass flow rate	383.45	386.055	Kg/s

The drop in the exhaust temperature with fogging system confirms the cooling that took place inside the system. Figure 5 shows the effect of temperature with fogging (cooling) and without fogging system (no cooling) on the efficiency of the gas turbine. The results show that the thermal efficiency of the gas turbine system decreases without fogging system (no cooling) and this was as a result of an increase

in ambient air temperature. Thus, the net power Output of the gas turbine cycle will decrease because of the increase in compressor power and the mass flow rate of the gases reduced in the process.

However, with fogging system (cooling), the thermal efficiency increases as a result of reduction in ambient air temperature which lowers the compressor power since a lower

Simulation of Gas Turbine Power Plant Using High Pressure Fogging Air Intake Cooling System

ambient temperature lead to higher air density and lower compressor power that in turn gives a higher net power.

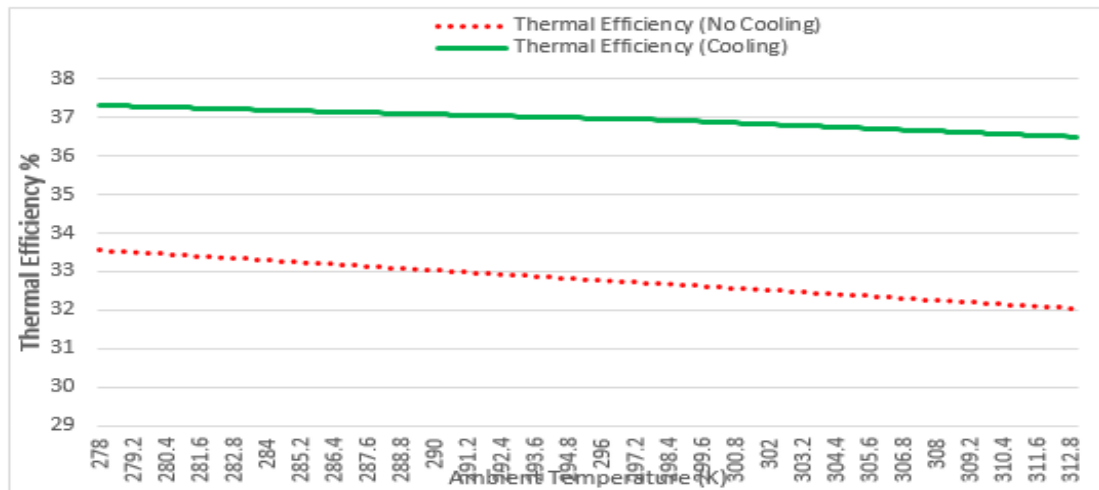

Figure 5. Effect of ambient temperature on thermal efficiency of gas turbine plant

Figure 6 shows that there was an improvement in net power due to incorporating air intake cooling system (high pressure fogging). As ambient air temperature increase, mass flow rate (the density of air with constant volumetric flow of gas turbine), decreases and compressor discharge temperature increases temperature.

Figure 7 is the plot of specific fuel consumption of simple gas turbine system and incorporation of fogging system. The results show that ambient air temperatures have a significant effect on specific fuel consumption on the gas turbine system. The ambient air temperature increases the specific fuel consumption and this was as a results of increase in compressor power resulting from higher intake ambient air

temperature. Also, the specific fuel consumption reduces when cooling air intake is incorporated due to lower ambient air intake.

Figure 8 is the plotted of heat rate of gas turbine system with incorporating of fogging system against ambient air temperature. The result obtained shows an increase in heat rate due to increase in ambient air temperature. This is because at a higher in take air temperature, compressor power increases with an increase in specific fuel consumption. Similarly, there is significant reduction in heat rate when air intake cooling system (high pressure fogging) is incorporated due to reduction in air intake to compressor since power require for compression is reduced.

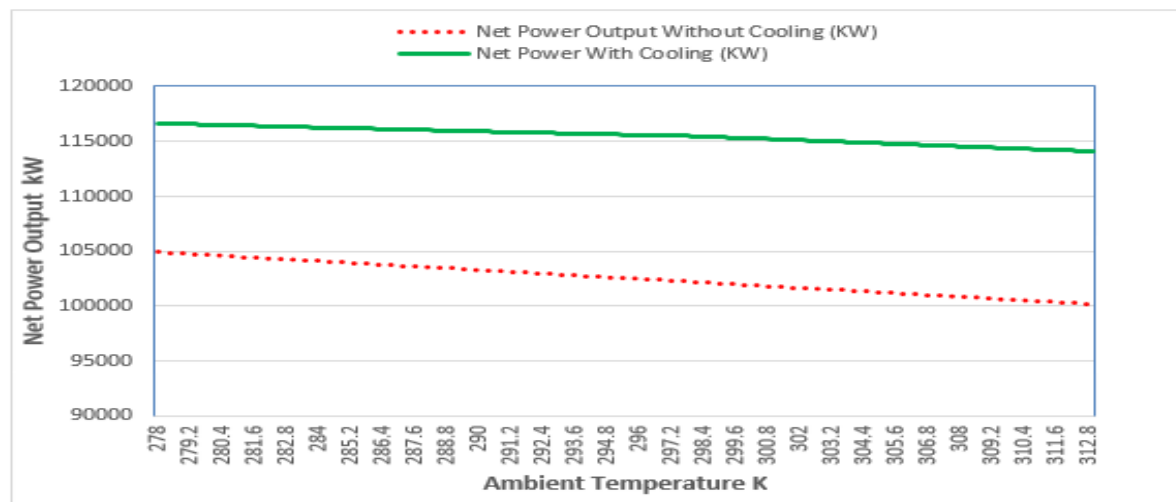

Figure 6. Effect of ambient temperature on net power output

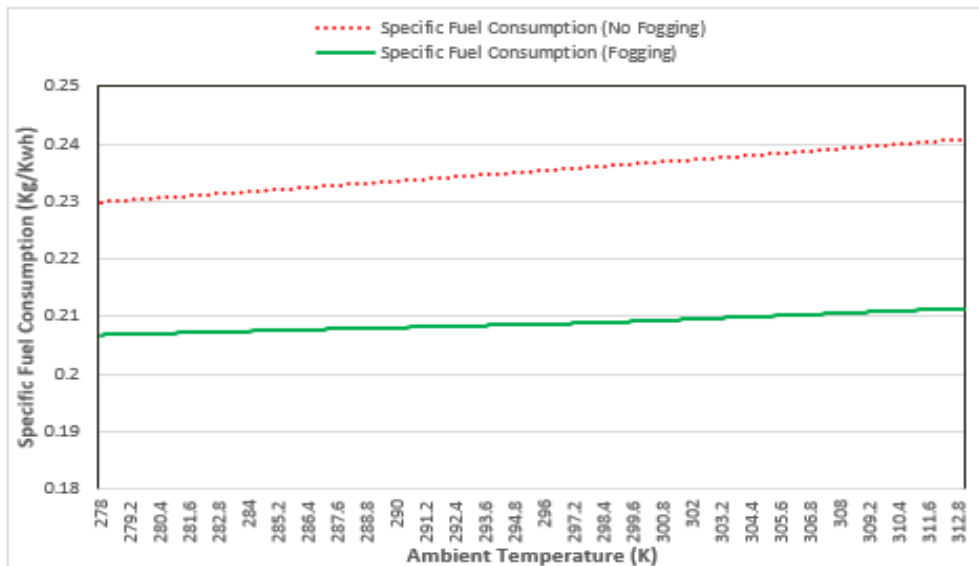

Figure7. Effect of ambient temperature on specific fuel consumption

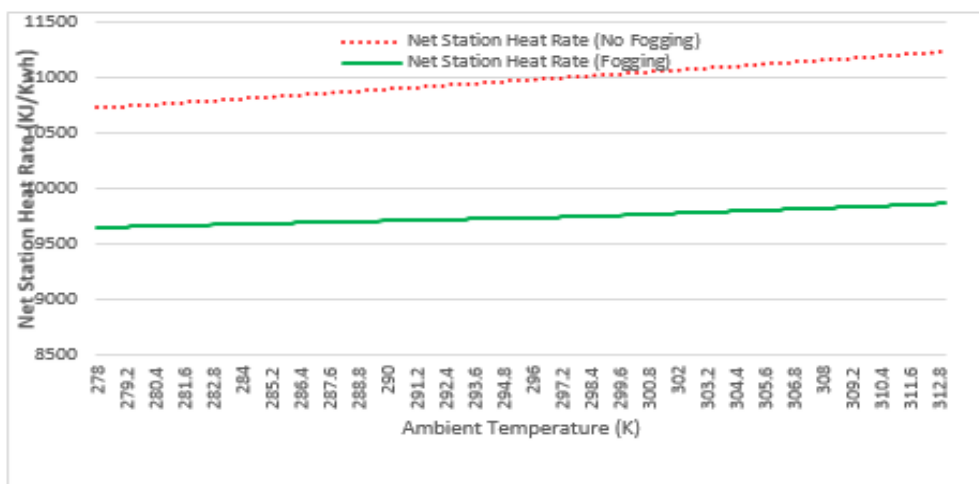

Figure8. Effect of ambient temperature on heat rate

CONCLUSION

In take air cooling systems are useful tools for increasing the net power generation capabilities of gas turbine power plants, especially in Sub-Saharan region. The process of reducing the intake air temperature of the gas turbine brings about an increase in the mass flow rate, thus, enhances its net output, efficiency, specific fuel consumption and heat rate. The results obtained with and without high pressure fogging system incorporated to a gas turbine proved that with high pressure fogging system, there was an increase in net power output, thermal efficiency and reduction in specific fuel consumption and heat rate. However, the opposite was the case when high pressure fogging system was not incorporated. Therefore, for better performance of gas turbine, high pressure fogging system should be incorporated.

ACKNOWLEDGEMENT

We are thankful to the manager of Ihovbor Gas Turbine Power Plant, Engr. Oluwaseun Fadare for granting us access to the plant and assisting us during the period of data collection.

REFERENCES

- [1] A. E. Nasser, M.A. and EL-kalay, M.A. 1991, A heat-recovery cooling system to conserve energy in gas – turbine power stations in the Arabian Gulf., Applied Energy, 38 (2),133-142.
- [2] Y.S. Kim., J.J. Lee., T.S. Kim., J.L. Sohn. 2011, Effects of syngas type on the operation and performance of a gas turbine in integrated gasification combined cycle, Energy Convers Manage, 52 (22), 62–71.
- [3] A.G. Kaviri, M.N. Jaafar, T. Mat Lazim, 2012, Modeling and multi-objective exergy based optimization of a combined cycle power plant using a genetic algorithm. Energy conversion management, 58, 94-103.

- [4] C.B. Meher-Homji and T.R. Mee, Gas Turbine Augmentation by fogging of inlet Air, proceeding of the 28thTurbomachinery Symposium, Houston Texas September, 1995
- [5] X. Shi, B. Agnew, D. Che, and J. Gao, 2010, Performance enhancement of conventional combined cycle power plant by inlet air cooling, inter-cooling and LNG cold energy utilization', Applied Thermal Engineering, 30, 2003 – 2010
- [6] T.K. Ibrahim, M.M. Rahman, A.N. Abdalla, 2011, Improvement of gas turbine performance based on inlet air cooling systems: A technical review', International Journal of Physical Sciences, 6 (4), 620-627
- [7] T.K. Ibrahim, M.M. Rahman, A.N. Abdalla, 2010, Study on the effective parameter of gas turbine model with intercooled compression process', Scientific Research and Essays, 5(23), 3760-3770
- [8] H. BarzegarAvval, I.P. Ahmadi, A.R. Ghaffarizadeh, M.N. Saidi, 2011, Thermo-economic-environmental multi-objective optimization of gas turbine power plant with preheater using evolutionary algorithm, Int. J. Energy Res, 35, 389-403
- [9] F.I. Abam, I. U. Ugot, and D. I. Igbong, 2011, Thermodynamic assessment of grid-based gas turbine power plants in Nigeria, J. Emerg. Trends Eng. Applied Sci., 2, 1026-1033
- [10] M. Farzaneh-Gord, and M. Deymi-Dashtebayaz, 2011, 'Effect of various inlet air cooling methods on gas turbine performance', Energy, 36, 1196–1205
- [11] I. Al-Tobi, 2009, Performance Enhancement of Gas Turbines by Inlet Air Cooling', International Conference on Communication, Computer and Power (ICCCP'09) Muscat, February 15-18, 165 – 170
- [12] Veiko, Microtechnology, 2nd ed., R. M. Osgood, Jr., Ed. Berlin, Germany: Springer-Verlag, 1998.
- [13] J. Breckling, Ed., The Analysis of Directional Time Series: Applications to Wind Speed and Direction, ser. Lecture Notes in Statistics. Berlin, Germany: Springer, 1989, vol. 61.
- [14] S. Zhang, C. Zhu, J. K. O. Sin, and P. K. T. Mok, "A novel ultrathin elevated channel low-temperature Poly-Si TFT," IEEE Electron Device Lett., vol. 20, pp. 569–571, Nov. 1999.
- [15] ASPEN HYSYS (2016), ASPEN version 9.0 ASPEN power generation and Refrigeration library manual. PSE version 9.0 ed. USA ASPEN Simulation Technology INC, 200 wheeler Road Burlington MA

AUTHORS' BIOGRAPHY

Achimnole Evaristus N., Master degree student, Faculty of Engineering, Department of Mechanical Engineering, University of Benin, Nigeria.

Ejiroghene Kelly Orhorhoro, PhD degree student, Faculty of Engineering, Department of Mechanical Engineering, University of Benin, Nigeria.

Monday Erhire Onogblotsere, PhD degree student, Faculty of Engineering, Department of Electrical/Electronic Engineering, University of Benin, Nigeria.

Citation: E. Achimnole, E. Orhorhoro and M. Onogblotsere, "Simulation of Gas Turbine Power Plant Using High Pressure Fogging Air Intake Cooling System", *International Journal of Emerging Engineering Research and Technology*, vol. 5, no. 5, pp. 16-23, 2017.

Copyright: © 2017 E. Achimnole, et al. This is an open-access article distributed under the terms of the Creative Commons Attribution License, which permits unrestricted use, distribution, and reproduction in any medium, provided the original author and source are credited.