

Voice Operated Intelligent Fire Extinguisher Vehicle

¹Meena Kumari, M.E and ²Mrs. Shimi S.L

¹Instrumentation and Control, NITTTR, Chandigarh

²Assistant Professor, Electrical Engineering Department, NITTTR, Chandigarh

**Corresponding Author: Meena Kumari, M.E, Instrumentation and Control, NITTTR, Chandigarh*

Received Date: 09-10-2017

Accepted Date: 30-10-2017

Published Date: 02-12-2017

ABSTRACT

This paper exhibits the exploration and usage of voice operated fire extinguisher vehicle. The vehicle is controlled through associated discourse input. The dialect input permits a client to collaborate with the robot which is recognizable to a large portion of the general population. The upsides of discourse actuated robots are sans hands and quick information input operations. The discourse acknowledgment framework is prepared in a manner that the robot is controlled in view of the guideline through the Speech Commands. The entire framework comprises of three subsystems, the speech recognition system, transmitter area furthermore, the collector segment (on vehicle). The outcomes demonstrate that proposed robot is equipped for controlling flame, evading obstructions what's more, comprehension the importance of speech orders.

Keywords: *Speech controlled robot, speech controlled fire extinguisher*

INTRODUCTION

Fire fighting and rescue is recognized as a risky mission. Fire fighters face risky situations when extinguishing fires and rescuing victims, it is an inevitable part of being a fire fighter. In contrast, a robot can function by itself or be controlled from a distance, which means that fire fighting and rescue activities could be executed without putting fire fighters at risk by using robot technology instead. In other words, robots decrease the need for fire fighters to get into dangerous situations. Further, if the robots replace or support fire fighter in missions, the load for fire fighters reduced. Moreover, one can each say nothing but there is the limit of fire department power. So it is impossible to extinguish fire and rescue many victims at a time in a huge disaster. In this case, the robot technology make possible to rescue much more victims [1], [2], [3], [4]. To make human lives easier and to make maximum use of time available.

TYPES OF FIRE EXTINGUISHER

Multipurpose (ABC) Dry Chemical

Multipurpose (ABC) dry chemical extinguishers contain an ammonium phosphate base which can be used on all types of fires and is the least expensive of the extinguishing agents. The most

common size is 2: A-10B:C and weights above five ponds.

Wet Chemical (K)

The class K extinguisher is the ideal choice for use on cooking appliances including deep fat fryers and solid fuel cooking appliances. They contain a low Ph potassium acetate base. The extinguishing agent discharges as a fine mist which helps prevent grease splash and fire re-flash while cooling the appliance.

Clean Agents

Clean agent fire extinguishers do not leave a residue and are rated ABC or BC depending on size. Halon 1211 is a clean agent that is commonly found around computer system and electronic equipment because of environment concerns, fire extinguishing clean agents known as halocarbons are now the recommended alternative.

Carbon Dioxide (CO₂)

Co₂ extinguishers may be used on most mechanical and electrical fires. Because they are less effective on ordinary combustibles (class A) fires, Co₂ fire extinguishers are usually only rated BC depending on the size of the extinguisher.

Pressurized Water

Pressurized water extinguishers are designed for use on ordinary combustible (Class A) fires only use of water on fires involving flammable liquids and energized electrical equipment can be very dangerous.

CORE HARDWARE USED

8051 Microcontroller is used to implement the project work. The general schematic diagram of 8051 microcontroller is shown in fig1. We can see 3 system inputs, 3 control signals and 4 ports (for external interfacing). A Vcc power supply and ground is also shown. System inputs are necessary to make the micro controller functional. So the first and most important of this is power, marked as Vcc with a GND (ground potential). Without proper power supply, no electronic system would work. XTAL 1 and XTAL 2 are for the system clock inputs from crystal clock circuit. RESET input is required to initialize microcontroller to default/desired values and to make a new start.

There are 3 control signals, EA, PSEN and ALE. These signals known as External Access (EA), Program Store Enable (PSEN), and Address Latch Enable (ALE) are used for external memory interfacing.

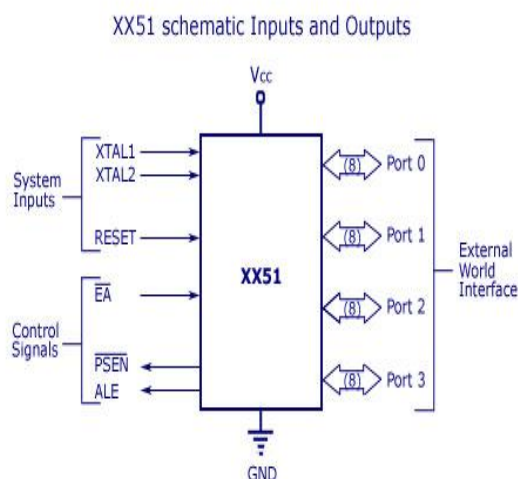

Figure1. Schematic diagram of 8051 microcontroller

INFERENCES DRAWN OUT OF THE LITERATURE REVIEW

The investigator after going through a large number of literatures divulges the following inferences:

- * Crew protection systems can only be designed for protection in low to moderate

intensity fire entrapments or burn over situations

- Ultraviolet sensors will be utilized for starting discovery of the fire.
- Automatic ringer framework, sensor can be executed effortlessly by the savvy utilization of microcontroller.
- Infrared detecting method can be executed effortlessly for flame locator.
- Ultrasonic sensor can likewise be utilized for detecting the fire yet it is exorbitant when contrasted with the infrared sensor.
- Fire quenchers can be observed on a continuous premise, adding to lower costs and expanded security.
- Speech initiated vehicle framework are sans hands and works quick.
- Advanced putting out fires innovation is attempting to make putting out fires more secure and more powerful with pressure water mist and CAFS (Compressed Air Foam System).
- Fire is very common danger and could be observed and counteracted utilizing remote sensor and on-screen character systems. [5],[6],[7].

PROPOSED WORK

The main objectives of this work are as follows:

- Construction of speech based intelligent fire extinguisher vehicle system.
- Live images feedback through wireless video camera.
- Obstacle detection capability
- Night vision capability

METHODOLOGY AND ALGO

The controlling gadgets of the entire framework are microcontrollers. Speech acknowledgment module, remote handset modules, deterrent locator, light, water stream splash, dc engines and bell are interfaced to microcontroller. At the point when the client bolstered the voice summons to the speech acknowledgment module, the microcontroller interfaced to it peruses the charge and sends applicable information of that order remotely utilizing handset module. This information is gotten by

Voice Operated Intelligent Fire Extinguisher Vehicle

the handset module on the mechanical vehicle and feeds it to microcontroller which acts in like manner on engines, pump and light. The vehicle is mounted with a camera which helps in survey the live pictures on TV.

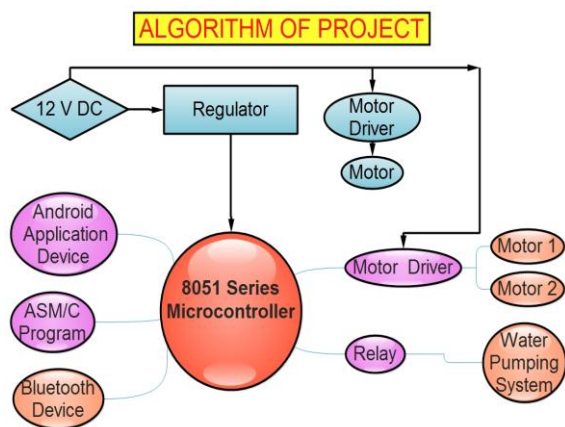

Figure2. Algorithm of project

CONCLUSION

Speech has difficulties to be recognized by an application. Since speech is distinctive for each speaker, May be quick, moderate, or changing in speed. May have high pitch, low pitch, or be whispered. Have generally changing sorts of ecological clamor. Can happen over any number of channels .Changes relying upon succession of phonemes, May not have unmistakable limits between units (phonemes), Limits might be pretty much particular relying upon speaker style and sorts of phonemes. Changes relying upon the semantics of the articulation has a boundless number of words, has phonemes that can be adjusted, embedded, or erased. In view of the plan standards and prerequisite, a model of

the framework for Voice Operated Fire Extinguisher Robot has been produced. The results are excellent.

REFERENCES

- [1] Manish kumbhare, SS kumbhalkar, Ratnesh malik, "Fire Fighting Robot: An Approach", Indian Streams Research Journal, Vol. 2, Issue 2, pp.1-7, March 2012.
- [2] Preeti Dhiman,Noble Tawra,Rakesh Nagar,Rishab Singh and Varun Kaushik," Voice Operated Intelligent Fire Extinguisher Vehicle", International Journal of Emerging Trends in Electrical and Electronics, Vol. 2,Issue 2,pp.43-47, April 2013.
- [3] D.Nichols, A.Canderle, I.knight and J.Leonard, "Development of Fire fighting Vehicle Crew Protection Systems", AFAC publication, Melbourne, Australia, pp.1-10, March 1996.
- [4] Taiser T.T.Barrous and Walter Fetter Lages, "Development of Fire Fighting Robot for Educational Competitions", 3rd International Conference on Robotics in Education (RiE), Prague, pp. 43-54, 2012.
- [5] R.A.Rosaline and Dr.P.Sumathi, "Fire Monitoring and Extinguishing Algorithm using Wireless Sensor and Actor Networks", International Journal of Advanced Smart Sensor Network Systems, Vol. 2, No.4, pp.23-32, October 2012.8-9456/2011.
- [6] Daniel J.Pack, Robert Avanzato and David J Ahlgren, "Fire Fighting Mobile Robotics and Interdisciplinary Design Comparative Perspectives", IEEE Transactions on Education, Vol. 47, No.3, pp.369-375, August 2004.
- [7] Kuo L.Su, "Automatic Fire Detection System Using Adaptive Fusion Algorithm For fire Fighting Robot", IEEE International Conference on Systems, Man and Cybernetics, Vol.2, pp.966-971, October 2006.

Citation: M. Meena Kumari and S. Shimi, "Voice Operated Intelligent Fire Extinguisher Vehicle", *International Journal of Emerging Engineering Research and Technology*, vol. 5, no. 8, pp. 14-16, 2017.

Copyright: © 2017 M. Meena Kumari, et al. This is an open-access article distributed under the terms of the Creative Commons Attribution License, which permits unrestricted use, distribution, and reproduction in any medium, provided the original author and source are credited.