

## Design and Construction of Solar Powered Phototherapy Device

Abioye Mayowa<sup>1</sup>, Salawu S. I<sup>2</sup>, Abioye Abiodun E<sup>3</sup>, Jonah.I<sup>4</sup>

<sup>1,2,4</sup> Department of Mechanical Engineering, Kogi State Polytechnic, Lokoja, Kogi State.

<sup>3</sup> Dept. of Electrical Electronics Engineering, Akanu Ibiam Federal Polytechnic, Unwana, Ebonyi State.

**\*Corresponding Author:** Abioye Mayowa, Department of Mechanical Engineering, Kogi State Polytechnic, Lokoja, Kogi State. Email: tayomayo1@mail.co.uk

### ABSTRACT

This study was carried out to design and construct a cost-effective and efficient solar-powered phototherapy device which can be implemented in areas where there are inadequate electricity and rural environment. Neonatal jaundice is the yellowish condition due to high-level bilirubin in a new born baby. This condition must be treated if the bilirubin level above 12 mg/dl. One of the common treatments is by using red and blue light phototherapy to convert bilirubin become more soluble in the water then easily excreted from the body. A microcontroller was used to regulate the radiation of light in the device and make it safe for the treatment of jaundice in a new baby. The device is powered by solar energy generated from the 24-volt monocrystalline solar panel, for charging deep cycle batteries via a charge controller. The wavelength of light is 460-490 nm with a minimum intensity of 30  $\mu\text{W}/\text{cm}^2$ . In this study, the phototherapy device is designed and tested. The red and blue light source consisted of thirty-six (36) high power Light emitting diode LED. Heat sink and fan are employed for the LED package cooling system. Solar power meter and spectrometer are used to analyse the intensity and wavelength produced by the LED.

**Keywords:** Light Emitting Diode LED, Neonatal jaundice, Solar energy, Phototherapy.

### INTRODUCTION

Neonatal jaundice is the yellowish condition due to high-level bilirubin in the new born baby. This condition must be treated if the bilirubin level above 12 mg/dl. One of the common treatment is by using blue light phototherapy to convert bilirubin become more soluble in the water then easily excreted from the body[1]. Phototherapy is the most common treatment for reducing high bilirubin levels that cause jaundice in a new born.

In the standard form of phototherapy, your baby lies in a bassinet or enclosed plastic crib (incubator) and is exposed to a special light that is absorbed by your baby's skin. Neonatal jaundice is treated by Phototherapy (PT) which is known to be a safe and non-invasive type of therapy. Approximately 60-80% of newborns have neonatal jaundice. If untreated, this could lead to brain damage or death. Phototherapy is the most common treatment for jaundice[2]. Newborns have differences in bilirubin production and elimination leading to a rise in bilirubin levels referred to as physiological

hyperbilirubinemia that is present in as many as 60% of all normal neonates in the first several days after birth. Pathological newborn hyperbilirubinemia can be caused by increased bilirubin production such as hemolysis or decreased bilirubin clearance such as prematurity[3].

A Wavelength of 430 - 490 nm and Irradiance of at least 30  $\text{uW}/\text{cm}^2/\text{nm}$  is required for phototherapy[4]. Arrays of Light emitting diode can be used to produce the required irradiance and wavelength for phototherapy equipment. High equipment costs limit the treatment of neonatal jaundice in developing countries such as Nigeria.

### LITERATURE REVIEW

#### Types of Phototherapy

Special blue lamps (Phillips TL 52/20W, Westinghouse 20 watt F20 T12BB) are the most efficient for neonatal phototherapy because they have more than twice the energy output at 450 nm than the standard blue bulbs. Investigators using these special blue bulbs report they have

achieved a more rapid reduction of serum bilirubin than with daylight or standard blue bulbs [5]. However, the special blue bulbs have been found to cause nausea and dizziness among the nursery staff. A combination of four special blue lamps placed in the centre of the phototherapy unit with two daylight lamps on either side has been found to provide excellent irradiance without producing significant discomfort to staff members. Non-fluorescent halogen lamps (spotlights) produce a more intense light over a smaller surface but are more expensive than fluorescents. If they are placed closer than 50 cm, halogen lamps, unlike fluorescent bulbs, incur the risk of burns to the infant.

Light-Emitting Diode (LED) lights are now commercially available for use in the United States and other countries[6]. India is a 2nd most populated country in the world and the birth rate is very high. According to market survey's, in India, every year 26 million infants are being prematurely born with low birth weight (lbw).

These LBW infants are generally kept in chambers referred to as "incubators" which are housings with controlled temperature and humidity. Since from the time incubators are introduced in the hospitals, the survival rate of premature babies has significantly raised up. Thus incubators are a highly important device in Intensive Care Unit's (ICU) at hospitals. This study is to design an Infant incubator with improved usability targeting low budget hospitals [7].

The Neo Blue LED systems incorporate optimal blue LED technology and are manufactured by Natus Medical Inc., San Carlos, CA, USA. Neo Blue LED's emit blue light in the 450-470 nm spectrums. They are the safest phototherapy devices available because they do not emit light in the ultraviolet and the infrared radiation range.

The virtual absence of heat when delivering overhead Neo Blue phototherapy should be less likely to cause insensible water loss. Fibre-optic phototherapy systems first appeared on the market in 1989. They are widely considered to be equally as effective as and more convenient than overhead lights. Light is delivered from a halogen bulb (bulb life is 450 hours) through a fiber optic cable and is emitted filtered from the sides and ends of fibers inside a plastic blanket which is protected by a disposable cover. Infants lie on the blanket or are held with the blanket

wrapped around them, and the need for eye patches otherwise required in neonatal phototherapy is eliminated[6].

The technology currently provides the clinician with three different modes of phototherapy delivery: fiber optic, low intensity, and high-intensity phototherapy[8]. For low-intensity phototherapy, overhead lamps are typically set at a distance of 50 cm from the patient. High-intensity phototherapy has been defined by the American Academy of Paediatrics as a spectral irradiance of at least 30 MW per square meter per nanometer. High-intensity phototherapy is achieved by using a unit with eight special blue lamps or Neo Blue LED systems 25 cm above the naked infant who is on a fiber optic phototherapy blanket in a bassinet while wearing a tie-on surgeon's mask as a diaper.

This method allows maximum skin exposure and achieves irradiance as high as 50uw/cm<sup>2</sup>/nm. However, as lamps are lowered close to the infant, there is an increase in the heterogeneity of irradiation, with a much greater increase at the center than at the periphery. Lining the bassinet with a white cloth produces greater homogeneity of irradiance and an increase in the amount of indirectly reflected irradiance. Home phototherapy [9], should be limited to otherwise healthy term infants who are older than 48 hours with bilirubin levels between and 15 and 20 mg/dl and no hemolysis. Parents have to be able to monitor the baby's temperature and hydration status. Home visits by a nurse experienced in evaluating newborns are performed, with results of bilirubin levels available on a timely basis.

## MATERIALS AND METHODS

The entire process for the development of the solar power phototherapy device is presented on the block diagram in Figure 1.

Based on the block diagram in Fig. 1, the device is powered by a solar power source and also has an alternative for main supply which is step-down with the aid of a transformer and rectified to 12 volts. The rectified voltage serves as an input to the optical sensor which senses the light and communicates with the microcontroller.

The microcontroller converts the analog voltage signal from the optical sensor to a digital signal. This feedback signal regulates the intensity of the light of the LEDs and sends the message to the display unit. The Liquid Crystal Display (LCD) displays the welcome note as well as the intensity of the LEDs.

## Design and Construction of Solar Powered Phototherapy Device

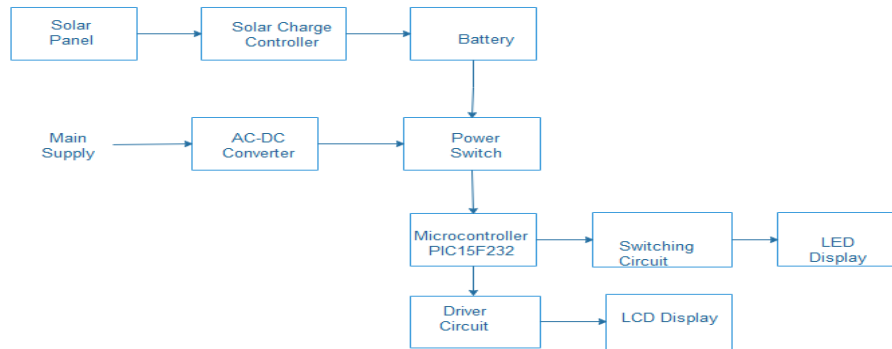

**Fig1.** Block Diagram: Solar Power Phototherapy Device

### Solar System Setup

A medium-sized solar panel of 255W, 24V, two batteries of 12V @ 100Ah each, 30A, 12/24V PWM solar charge controller. The Solar Panel converts the sunlight into electricity as direct current (DC). These are typically categorized as monocrystalline or polycrystalline.

Monocrystalline is costlier and efficient than the polycrystalline panel. Solar panels are generally rated under standard test conditions (STC): irradiance of 1,000 W/m<sup>2</sup>, the solar spectrum of

AM 1.5 and module temperature at 25°C. The solar panel size is selected in such a way that it will charge the battery fully during the one day time. During the 12hr day time, the sunlight is not uniform it also differs according to your location in the globe. So we can assume 4 hours of effective sunlight which will generate the rated power.

Total WP of PV panel capacity needed =  $475\text{Wh} / 4 = 118.75\text{ W}$

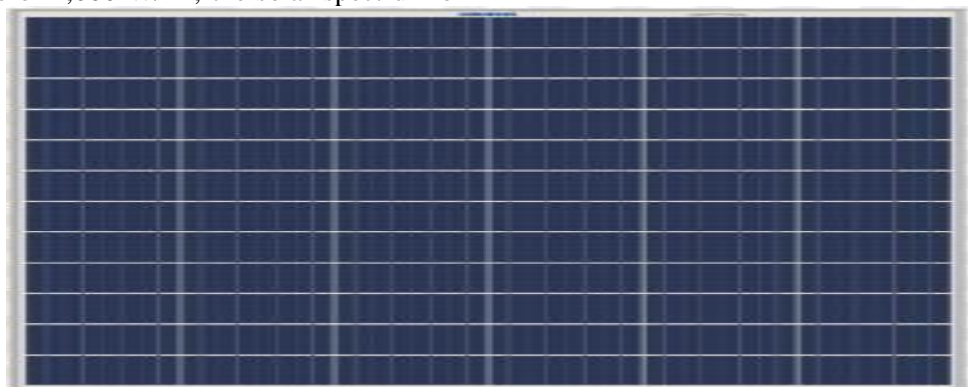

**Fig2.** A Solar Panel

By taking some margin we choose a 120 Watt, 12V solar panel suitable for charging the 12V battery. But actually, the Solar panel voltage is around 17V or more.

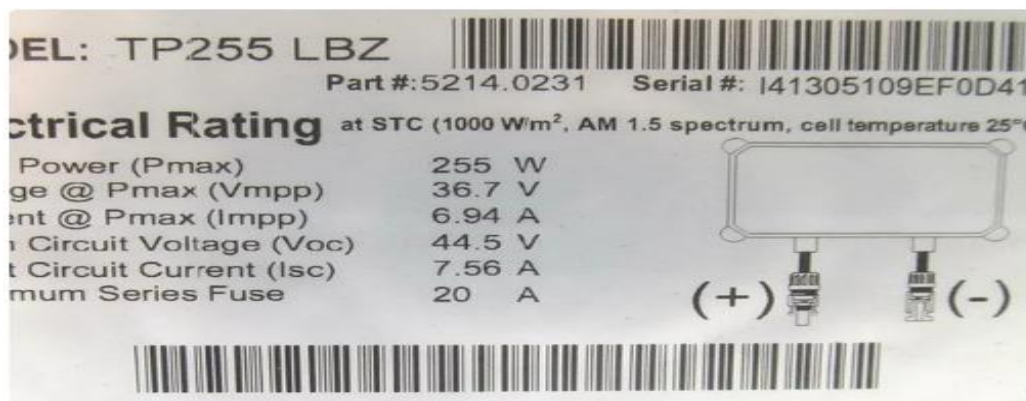

**Fig3.** Specification of the Solar Panel

The above problem is solved by using a battery to store the solar power during the day time and use it according to your choice. It will provide a

constant source of stable, reliable power. But the solar battery is a deep-cycle lead-acid battery that allows for partial discharge and

## Design and Construction of Solar Powered Phototherapy Device

allows for deep slow discharge. The lead acid tubular battery is perfect for a solar system.

### Rating of Battery

Batteries capacities are rated in term of Ampere Hour.

Power=Voltage X Current

Watt Hour =Voltage (Volts) x Current (Amperes) x Time (Hours)

Battery Voltage = 12V (as our system is 12V)

Battery capacity= Load /Voltage = 475/12 = 39.58 Ah

Practically batteries are not ideal, so we have to consider the loss. Let the battery loss is 15%.

So battery capacity required is  $39.58 / 0.85 = 46.56$  Ah

For better battery life, they are not allowed to discharge fully (100%). For flooded lead-acid battery, 60% depth of discharge (DOD) is considered as good practice.

So Capacity Required =  $46.56 / 0.6 = 77.61$  Ah

You can select a deep cycle lead acid battery with capacity more than 77.61 Ah. We, therefore, round off to 100 Ah (Two units are shown in Figure)



Fig4. Deep Cycle Battery

A solar charge controller is a device which is placed between a solar panel and a battery. It regulates the voltage and current coming from your solar panels. It is used to maintain the proper charging voltage on the batteries. As the input voltage from the solar panel rises, the charge controller regulates the charge to the batteries preventing any overcharging.

The solar power systems use 12-volt batteries; however, Solar panels can deliver far more voltage than is required to charge the batteries. By, in essence, converting the excess voltage into amps, the charge voltage can be kept at an optimal level while the time required to fully charge the batteries is reduced. This allows the solar power system to operate optimally at all times.

### Rating of Charge Controller

Since our system is rated 12V, a Charge controller is also 12V

Current rating = Power output of Panels / Voltage = 120 W/ 12V = 10 A

By taking 20% margin, we choose a 10 x1.2 = 12A charge controller. But the next rating controller available in the market is 15A. So we choose a Charge Controller of 12 V and current rating of 15 A.

## DESIGN IMPLEMENTATION OF THE PHOTOTHERAPY CIRCUIT

The design and construction of the light source which consisted of LED panel, LED circuit, intensity light controlled circuit and LED driver circuit. LED panel would be designed by giving the dimension of 92 inches square of an octagon in order to allow the brightness to cover the whole infant body by using the blue LED which had the wavelength of 460 nanometers in order to reduce the concentration of bilirubin on the baby.

In the LED circuit, the resistor was necessary to limit current to prevent damaging the LEDs in the circuit. The resistance of the LED series circuit could calculate by using equation (1)

$$R = \frac{V_S - V_F}{I_F} \dots \dots \dots 1$$

Where R was resistance,  $V_S$  was the voltage of power supply,  $V_F$  was the forward voltage in volts which dropped across the LED and  $I_F$  was the forward current in amperes of LED. From the description of the red LED light, it showed that there would be a forward voltage of 1.8 Volts and a forward current of 20 mA but actually used 15 mA which was 75% of

## Design and Construction of Solar Powered Phototherapy Device

maximum current. Then the resistance which was connected in series with 6 bulbs in the circuit, as shown in equation (2)

$$R = \frac{12V - 6(1.8V)}{15mA} = 80\Omega \dots \dots \dots 2$$

Consequently, it was suitable to use the resistance 100 Ω 1/8 W in LED circuit to connect in series with the red LED light, which was 6 bulbs connected in parallel, total of 3 sets and there were 18 bulbs and the blue LED light, which was also 6 bulbs connected in parallel, making a total of 36 sets.

The intensity light control circuit was used for controlling the suitable brightness for treatment. The intensity of the light controller circuit was used LM 324 to generate Pulse Width Modulation (PWM) to control the brightness of the light source which was suitable for treatment. LED driver circuit used to drive the current in 36 LEDs. From the calculation, the total current was used 0.48A in 36 LED bulbs and the total current in LED driver circuit required 1A in practice.

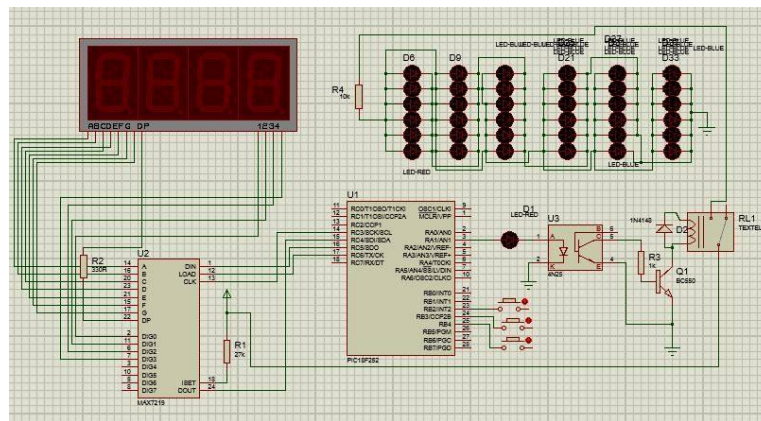

**Fig5.** The complete circuit Design

In circuit design, the LEDs used 12 volts and the microcontroller used 5 volts, then the circuit used IC optocoupler to separate current in the LEDs and the microcontroller due to prevent damage with the microcontroller. The LED driver circuit of the research was designed as shown in figure 2.

The design of the light intensity adjustment system and the timer system for phototherapy used microcontroller PIC18F252. The details were as followed.

The microcontroller PIC18F252 with 32 kB of program memory and 256-byte data memory runs at 4-10 megahertz, which was suitable for use in the project. It was divided into 2 parts: Hardware and Software as follows. Hardware part consisted of microcontroller PIC18F252 in signal processing. The microcontroller RC2 RB2-RB4 and PC0-PC1port were connected to the switch in order to receive data. The RA2 port was connected to the Buzzer. The RA3 port was connected to LDR in order to measure the light intensity and used the RA2 port to connect to the LED driver LED in order to drive the LEDs in the panel. The processed data was passed into RC port which was connected to the 7-segment display in order to show data on a screen. By adopting the PIC microcontroller

converted an analog signal to 10-bit digital (ADC). If the voltage input to ADC of PIC microcontroller was 5 V and a conversion resolution of 255 due to the 10-bit ADC selected, then the resolution from converting could be calculated from equation (3).

$$\text{Resolution} = \frac{5V}{2550} = 1.96mV \dots \dots \dots 3$$

Therefore, the step of resolution at each step that ADC was used to convert to 5 V was 1.96 mV. A10 MHz-crystal in crystal circuit was used to generate a time signal to determine the frequency of the clock in the operation of the LED and each of time treatment. The timer counted in each second from 1 second to 60 seconds and in minutes from 1 minute to 60 minutes, so it would advance to count in an hour. When the device was in mode “Time on”, the light source was bright until the end of time setting after that the device was in mode “Time Off” the light source was darkness. For input system and display, the research had adopted micro-switch to use as the input of the device. Input system used three micro-switches total to connect with a microcontroller.

A seven-segment digit display 4 alphabets size 0.56 inches type common cathode was used in

## Design and Construction of Solar Powered Phototherapy Device

order to show data enough and clearly see data from a distance. The digit display connected with IC Max7219 as shown in Figure 6, in order

to receive the command from the microcontroller to control the display output.

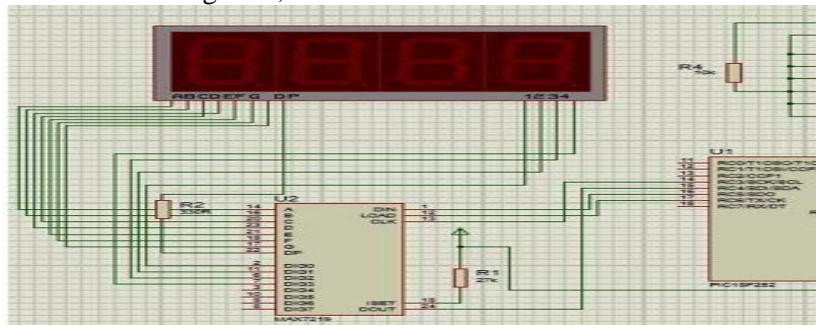

Fig6. Display part

When the LEDs were bright, there was LDR which measured the intensity of light from the LED panel and send data to process in the microcontroller to determine the total intensity of light that the LED panel could be provided.

In this research, the adjustment of light intensity came from the light source. The measurement was done by Phototherapy Radiometer and recorded the output in digital data by obtaining it from A/D conversion in the microcontroller. The test would be done 20 times.

## RESULTS AND DISCUSSION

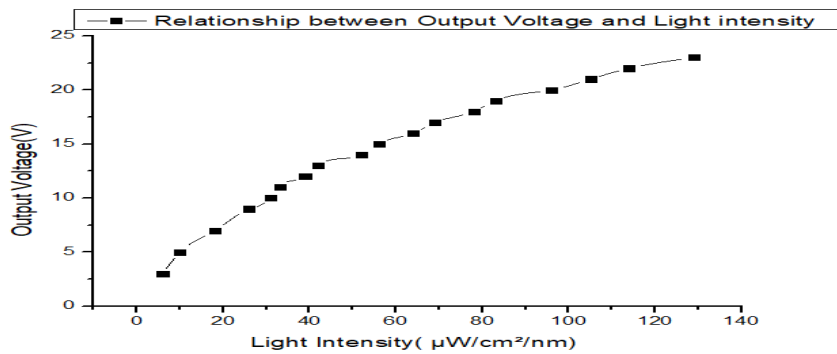

Fig7. Light Intensity Circuit Test Graph

The effectiveness of a phototherapy device is dependent on the amount of irradiance i.e. intensity and wavelength of the light incident on the baby being treated. It was observed that the graph of the improved device is similar to the

standard Neo-heliotherapy device used to benchmark the developed device. This shows a correlation between the devices. The major difference is that the light-source was improved as well as the irradiance control.

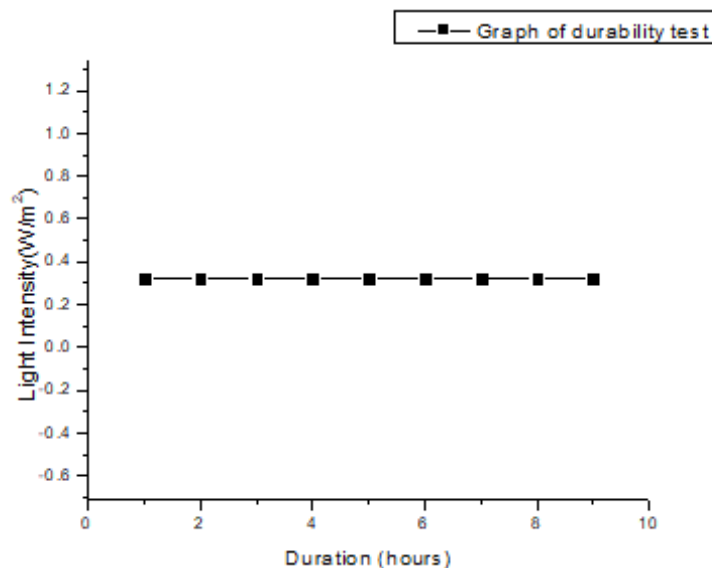

Fig8. Durability Test Graph

## Design and Construction of Solar Powered Phototherapy Device

For the durability, the device was turned on for nine hours nonstop, shown in figure 8. The light intensity remained constant for the test duration. This test is needed since the therapy can be performed for hours.

### CONCLUSION

The design of phototherapy for neonatal jaundice device has been conducted. This a low-cost device prototype design which can be enhanced and made affordable for clinics and hospitals. Based on the test measurement, the device was able to produce a light intensity of 0.3 W/m<sup>2</sup> with a wavelength of 460 nm. Also, the ability to control the irradiance of the device gave the device a better advantage over the conventional device. Based on this result it can be concluded that the device met the requirement for treatment of neonatal jaundice phototherapy.

### ACKNOWLEDGMENT

Our appreciation goes to the Department of Mechanical Engineering, Kogi State Polytechnic, Lokoja, Nigeria and TETFUND for providing the laboratory facility for this research work.

### REFERENCE

- [1] C. Series, "Design of phototherapy device for neonatal jaundice using high power blue LED Design of phototherapy device for neonatal jaundice using high power blue LED," pp. 2–6, 2019.
- [2] S. M. Reda and K. A. Mohammad, "The Improvement of the Irradiance Uniformity in LED Phototherapy to Match the Standard Requirements," *Br. J. Appl. Sci. Technol.*, vol. 4, no. 35, pp. 4939–4944, 2014.
- [3] M. Yurdakök, V. Fanos Cagliari, M. Mussap Genoa, A. Del Vecchio Bari, and B. Sun Shanghai, "Phototherapy in the newborn: what's new?," *J. Pediatr. Neonatal Individ. Med.*, vol. 4, no. 2, p. 40255, 2015.
- [4] F. Ko, N. Ripp, and S. Wulf, "Bilirubin Phototherapy Device," p. 80.
- [5] D. Ruscansky *et al.*, "DESIGN A LOW COST NEONATAL INCUBATOR Electronics and Mechanical Department Wentworth Institute of Technology."
- [6] M Zauk, "Phototherapy: A Simple and Safe Treatment for Neonatal Jaundice," *J. Pediatr. Neonatal Care*, vol. 2, no. 3, pp. 8–10, 2015.
- [7] S. N. Sreenath, S. Kumar, H. S. Lohit, and M. Student, "Design of an Infant Incubator for Cost Reduction and Improved Usability for Indian Health Care Centers," *SASTECH J.*, vol. 11, no. 2, pp. 82–89, 2012.
- [8] M. AF, "Evaluation of phototherapy devices.," *Indian Pediatr*, vol. 48, no. 8, p. 656; author reply 656-7, 2011.
- [9] T. Colbourn and C. Mwansambo, "Sunlight phototherapy for neonatal jaundice—time for its day in the sun?," *Lancet Glob. Heal.*, vol. 6, no. 10, pp. e1052–e1053, 2018

**Citation:** Abioye Mayowa, Salawu S. I *et al.* "Design and Construction of Solar Powered Phototherapy Device", *International Journal of Emerging Engineering Research and Technology*, 7(2), 2019, pp.17-23

**Copyright:** © 2019 Jincai Chen. This is an open-access article distributed under the terms of the Creative Commons Attribution License, which permits unrestricted use, distribution, and reproduction in any medium, provided the original author and source are credited.